



UNITEX

APPAREL



BAGS



SEWN BAG MADE UP IN CANVA CLOTH WITH REINFORCED GRABBERS, VARIOUS CUSTOMIZABLE COLORS. AVAILABLE TECHNIQUES: DTF, SERIGRAPHY

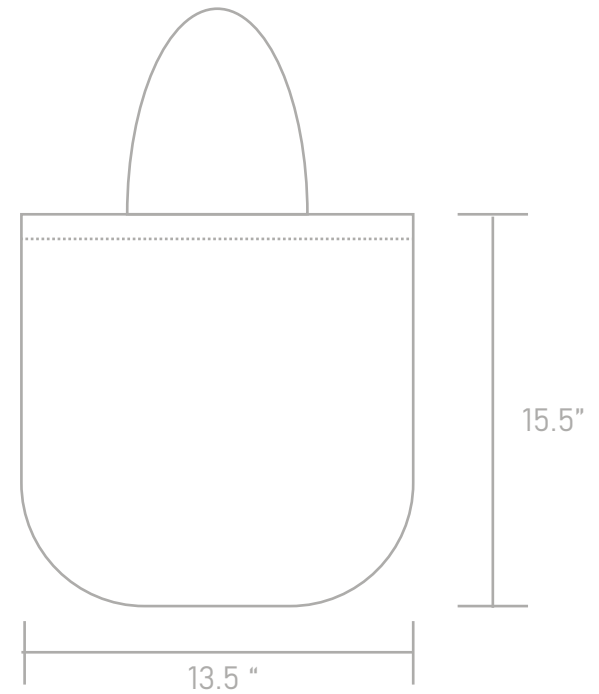

AVAILABLE COLORS





SEWN BAG MADE UP IN CANVA CLOTH, ROUND CORNERS
WITH REINFORCED GRABBERS, SEVERAL GRABBERS COLOR
USED TECHNIQUES: DTF, SERIGRAPHY, EMBROIDERY

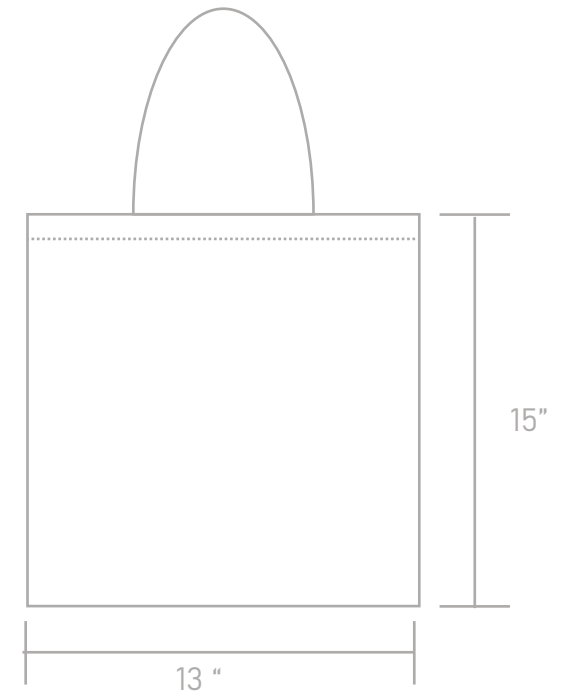

AVAILABLE COLORS



NONWOVEN BAG WITH ROUND CORNERS

BAGSF003



SEWN BAG MADE UP IN NONWOVEN CLOTH WITH REINFORCED GRABBER. SEVERAL GRABBER COLORS USED TECHNIQUES: DTF, SERIGRAPHY.

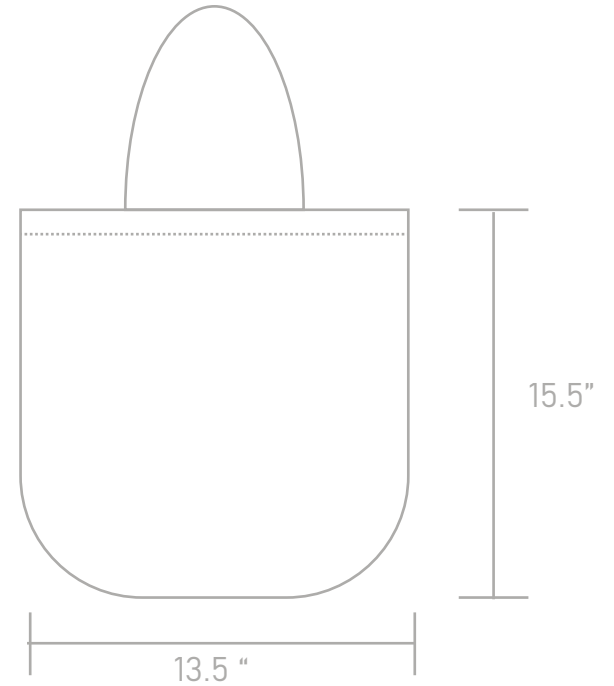

AVAILABLE COLORS



SQUARED NONWOVEN BAG

BAGSF004



SEWN BAG MADE UP WITH NONWOVEN CLOTH WITH REINFORCED GRABBERS,
USED TECHNIQUES: DTF, SERIGRAPHY.

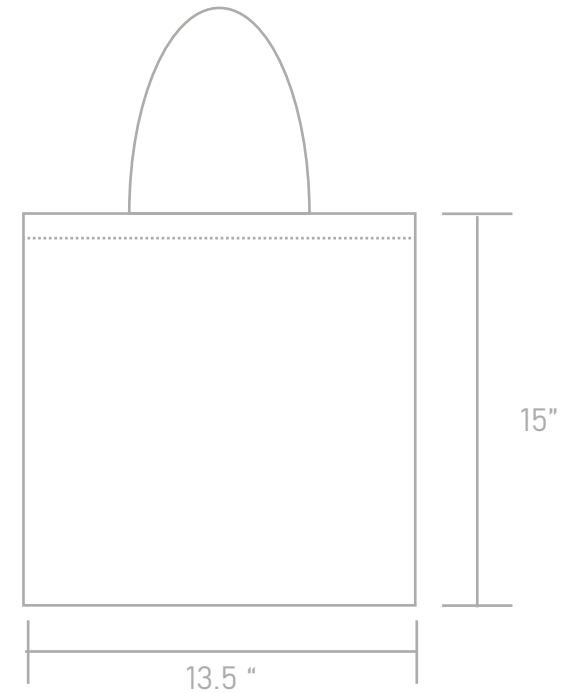

AVAILABLE COLORS





SEWN BAG MADE UP IN OXFORD CLOTH WITH REINFORCED GRABBERS, SEVERAL GRABBERS COLORS USED TECHNIQUES: DTF, SERIGRAPHY AND SUBLIMATION

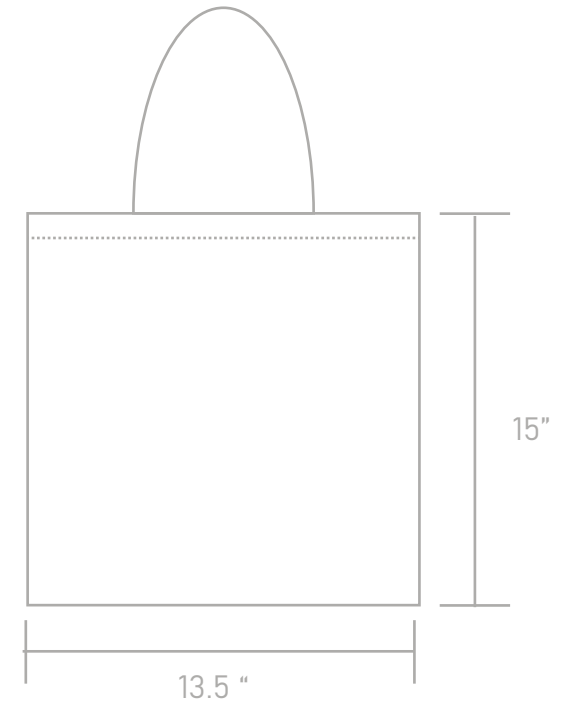

AVAILABLE COLORS



OXFORD BAG WITH ROUND CORNERS

BAGSF006



SEWN BAG MADE UP IN OXFORD CLOTH, ROUND CORNERS WITH REINFORCED GRABBERS, SEVERAL GRABBERS COLORS USED TECHNIQUES: DTF, SERIGRAPHY AND SUBLIMATION

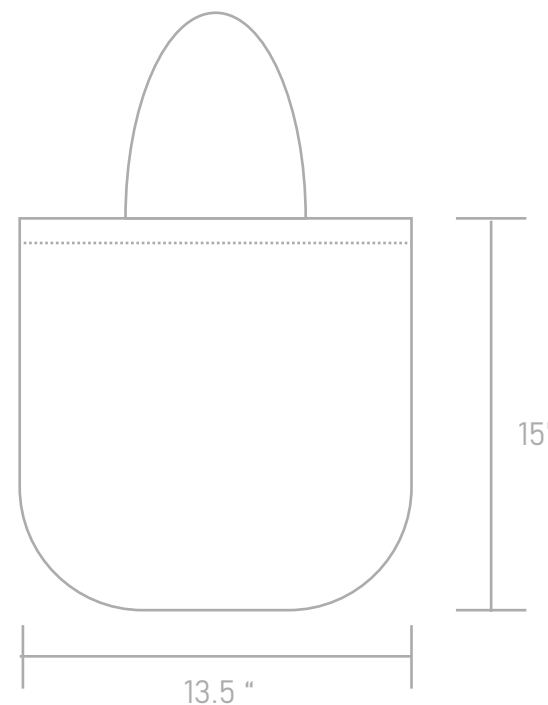

AVAILABLE COLORS



GROCERY LAMINATED BAG

BAGSF007

BAGSF008

BAGSF009

SEWN BAG MADE UP IN NONWOVEN LAMY WITH REINFORCED GRABBERS, SEVERAL GRABBERS COLORS
USED TECHNIQUES: DTF, SERIGRAPHY AND SUBLIMATION

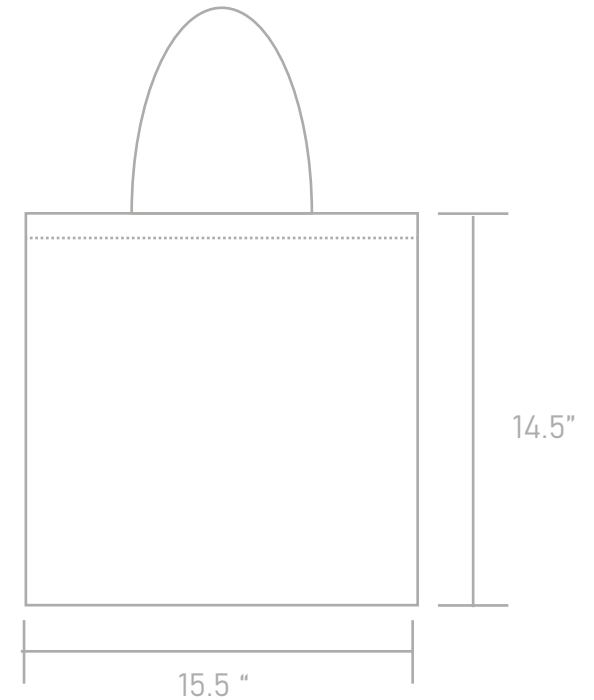

AVAILABLE COLORS



POLY SILVER BAG

BAGCF001



SEWN BAG MADE UP IN POLY SILVER CLOTH WITH REINFORCED GRABBERS, SEVERAL COLORS AVAILABLE
USED TECHNIQUES: DTF, SERIGRAPHY AND SUBLIMATION

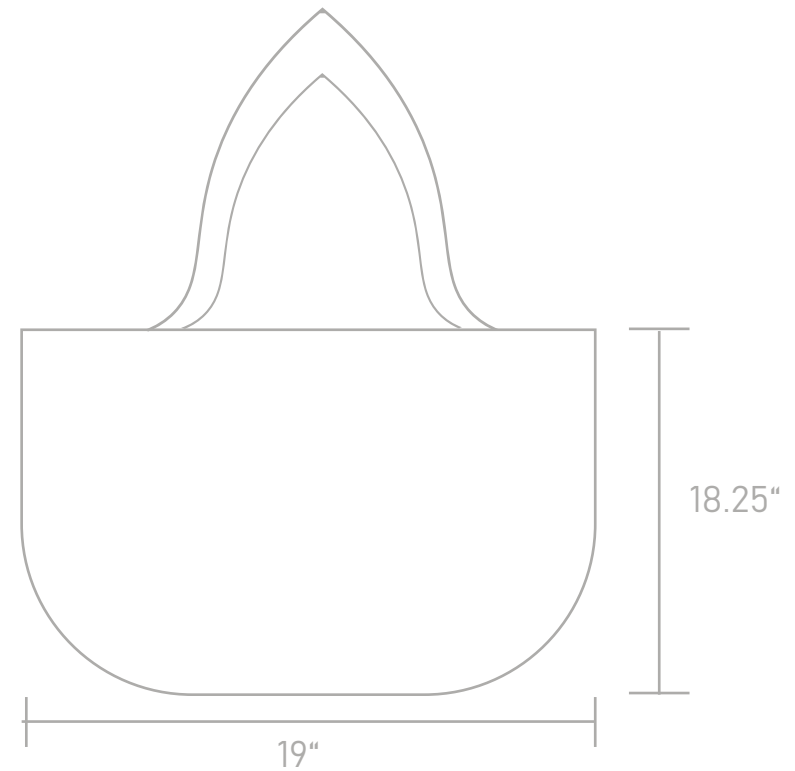

AVAILABLE COLORS



NONWOVEN BAG

BAGCF003



SEWN BAG MADE UP IN LAMY CLOTH WITH REINFORCED GRABBERS. SEVERAL COLORS AVAILABLE.
TECHNIQUES: DTF, SERIGRAPHY AND SUBLIMATION

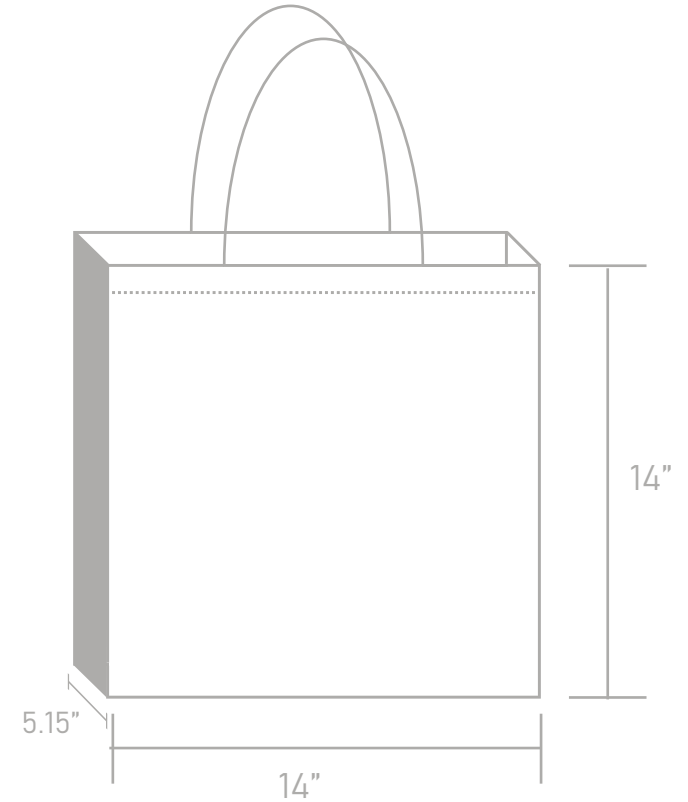

AVAILABLE COLORS



OXFORD SHOPPING BAG

BAGCF006

SEWN BAG MADE UP IN OXFORD CLOTH WITH REINFORCED GRABBERS, SEVERAL COLORS AVAILABLE
TECHNIQUES: DTF, SERIGRAPHY AND SUBLIMATION.

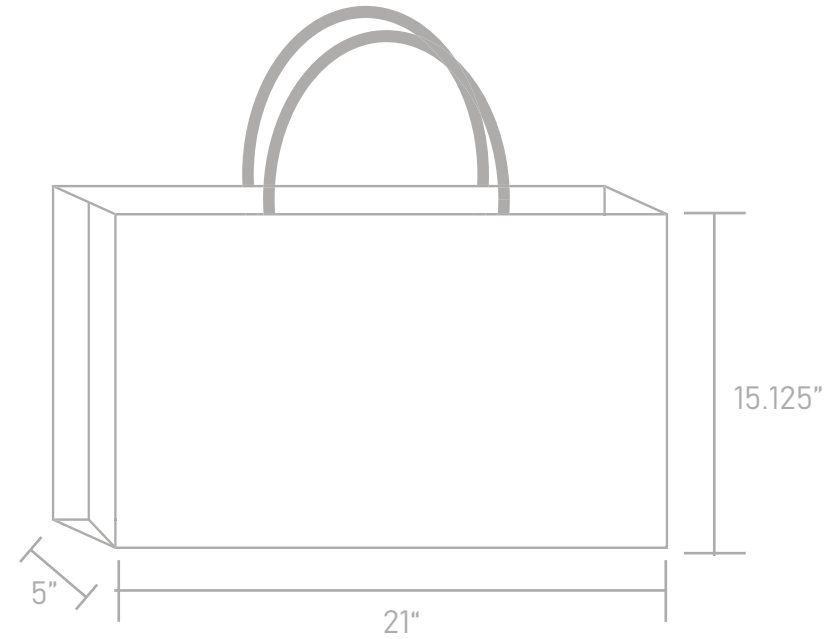

AVAILABLE COLORS



REINFORCED OXFORD BAG

BAGCF009

SEWN BAG MADE UP IN OXFORD WITH REINFORCED BAGGERS.
COLORS AVAILABLE.
TECHNIQUES: DTF, SERIGRAPHY AND SUBLIMATION.

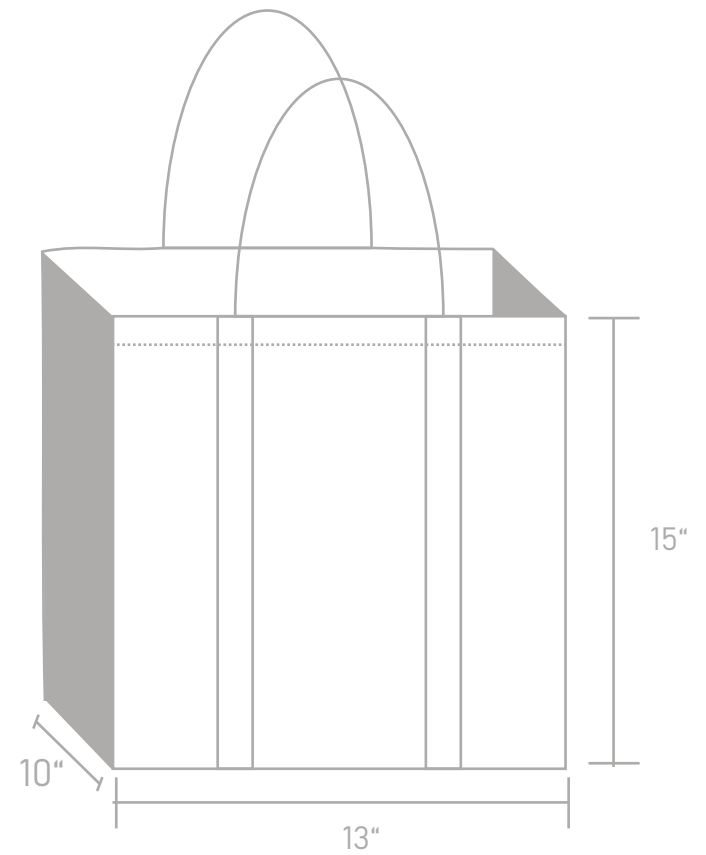

AVAILABLE COLORS



BAG WITH ROUND CORNERS

BAGCF012



SEWN BAGS MADE UP IN NONWOVEN CLOTH WITH REINFORCED GRABBERS. COLORS AVAILABLE. TECHNIQUES: DTF, SERIGRAPHY AND SUBLIMATION.

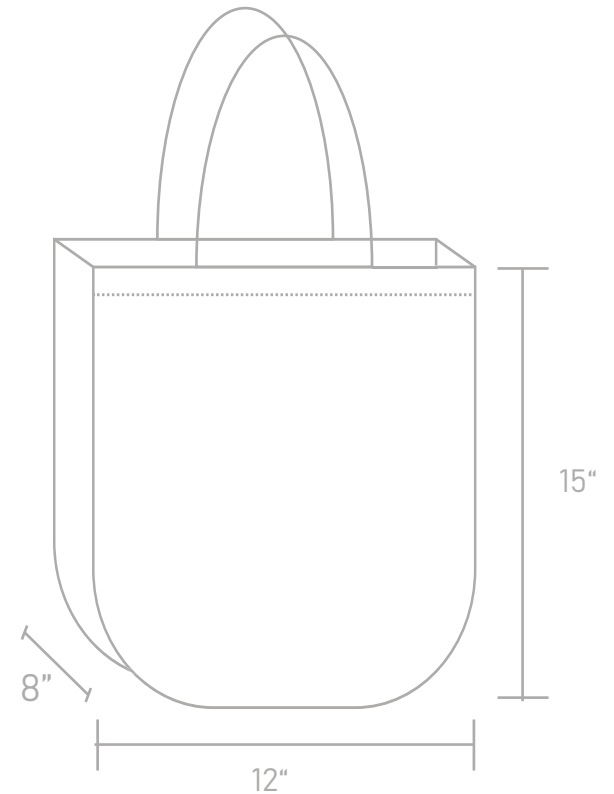

AVAILABLE COLORS





SEWN BAG MADE UP IN DENIM CLOTH WITH REINFORCED GRABBERS. LIGHT AND DARK COLORS AVAILABLE.

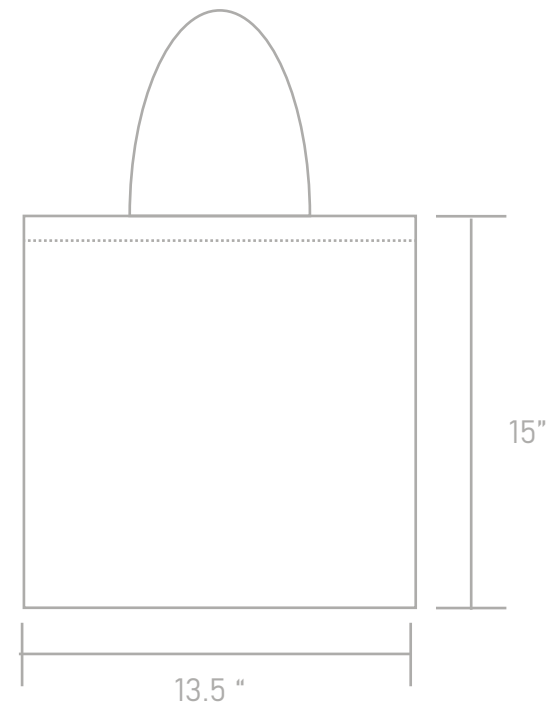

THIS PRODUCT CAN BE FULLY SUBLIMATED





SPORT BAG WITH BELTS FOR BETTER SUPPORT, VARIOUS GRABBERS AND CLOTH COLORS.
TECHNIQUES: DTF, SERIGRAPHY AND SUBLIMATION.

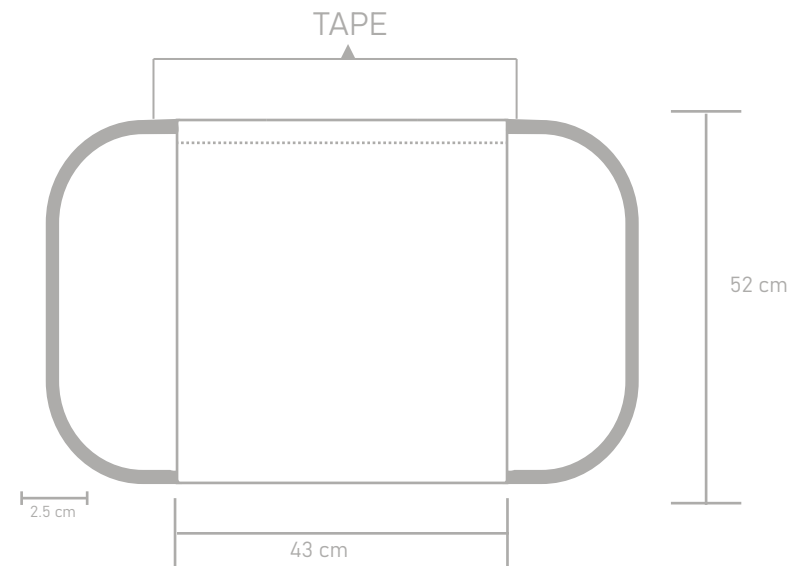

LOREM IPSUM
AVAILABLE COLORS
THIS PRODUCT CAN BE FULLY SUBLIMATED



POCKETBOOK BAG

SEWN BAG MADE UP IN NONWOVEN CLOTH WITH REINFORCED BAGGERS. COLORS AVAILABLE.

TECHNIQUES: DTF, SERIGRAPHY AND SUBLIMATION.

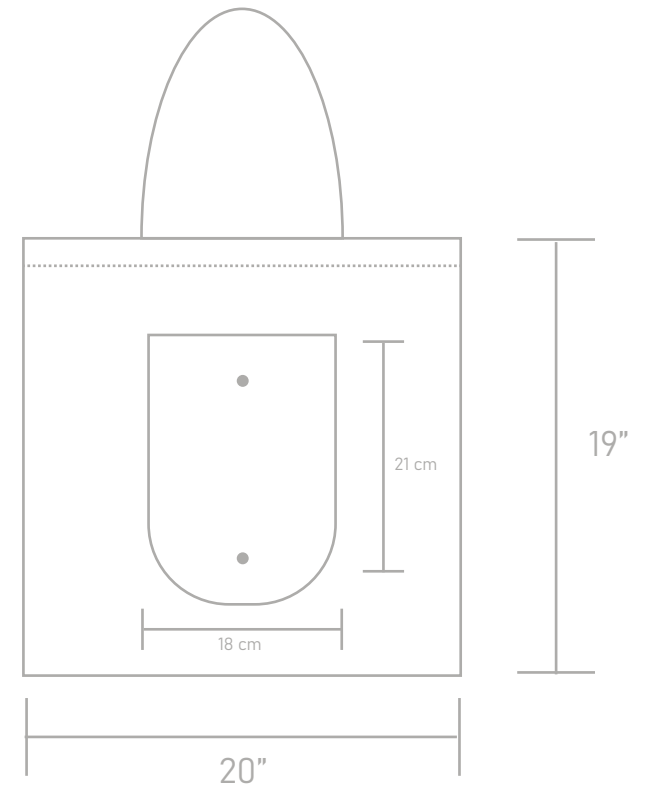

AVAILABLE COLORS





CAPS

CAP MADE UP IN TRENCH COAT WITH EYELETS.
CUSTOMIZE TECHNIQUES:
EMBROIDERED, SERIGRAPHY, DTF



AVAILABLE COLORS



TRENCH COAT AND MESH CAP.
CUSTOMIZE TECHNIQUES:
EMBROIDERED, SERIGRAPHY, DTF



AVAILABLE COLORS



SUBLIMATED MESH CAPS

CAPGB004

TRENCH COAT AND MESH CAP.
CUSTOMIZE TECHNIQUES:
EMBROIDERED, SERIGRAPHY, DTF



AVAILABLE COLORS



EMBROIDERED MESH CAPS

CAPGB004

TRENCH COAT AND MESH CAP.
CUSTOMIZE TECHNIQUES:
DTF AND EMBROIDERED SUBLIMATION



AVAILABLE COLORS



TRENCH COAT WITHOUT EYELETS, SEVERAL
COLORS AVAILABLE
CUSTOMIZE TECHNIQUES:
EMBROIDERED, SERIGRAPHY, DTF



AVAILABLE COLORS



PLAIN TRENCH COAT CAP.
CUSTOMIZE TECHNIQUES:
EMBROIDERED, SERIGRAPHY, DTF



AVAILABLE COLORS



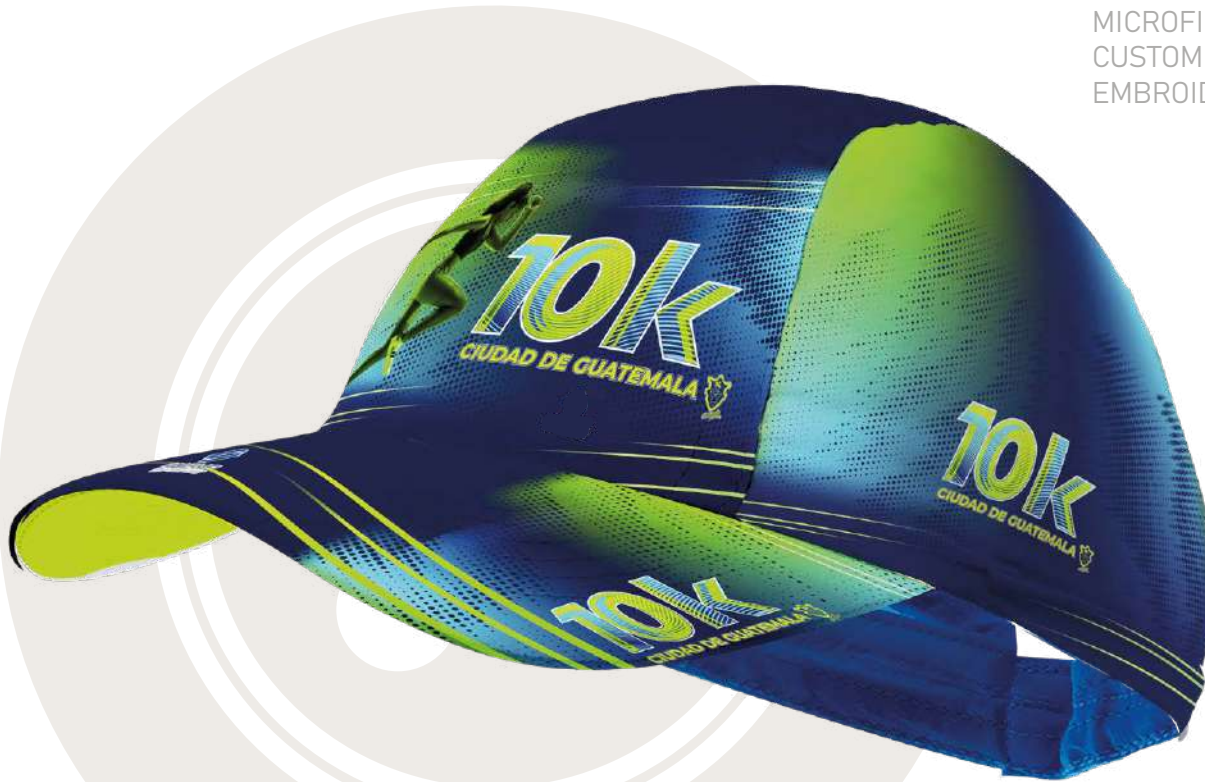

MICROFIBER CAP.
CUSTOMIZE TECHNIQUES:
EMBROIDERED, SERIGRAPHY, DTF



AVAILABLE COLORS





TRENCH COAT VISOR
CUSTOMIZE TECHNIQUES:
EMBROIDERED, SERIGRAPHY, DTF



AVAILABLE COLORS



BUCKLE, BELT BUCKLE, SNAP, AND HOOK&LOOP
BACK CLOSURES AVAILABLE
FULL COLOR SUBLIMATION AVAILABLE



CUSTOMIZE HAT
CUSTOMIZE TECHNIQUES:
EMBROIDERED, SERIGRAPHY, DTF AND
SUBLIMATION

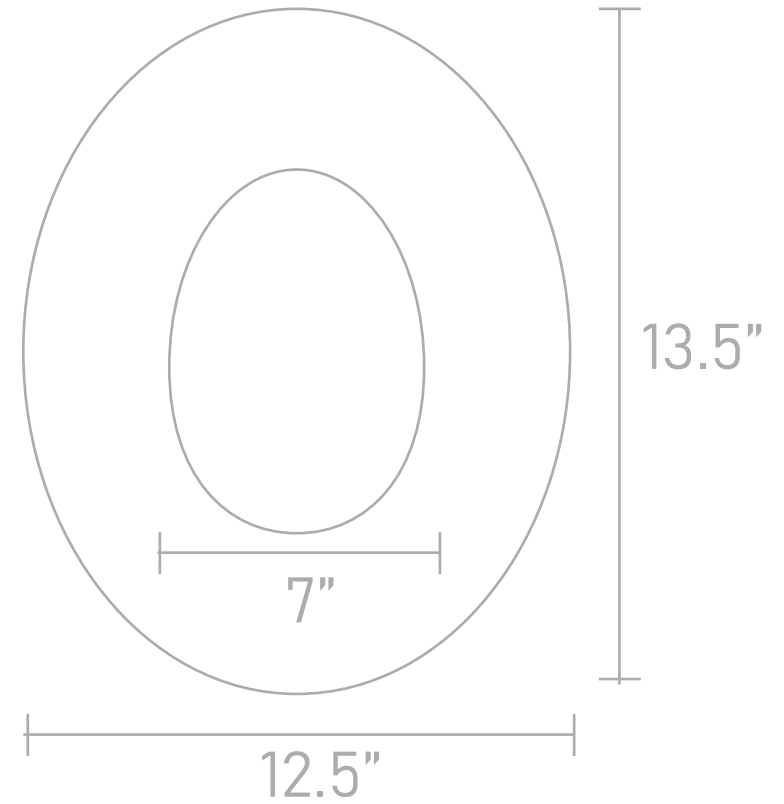

AVAILABLE COLORS



BUCKLE, BELT BUCKLE, SNAP, AND HOOK&LOOP
BACK CLOSURES AVAILABLE
FULL COLOR SUBLIMATION AVAILABLE





T-SHIRTS



T-SHIRTS
US SIZE S M L XL 2XL 3XL

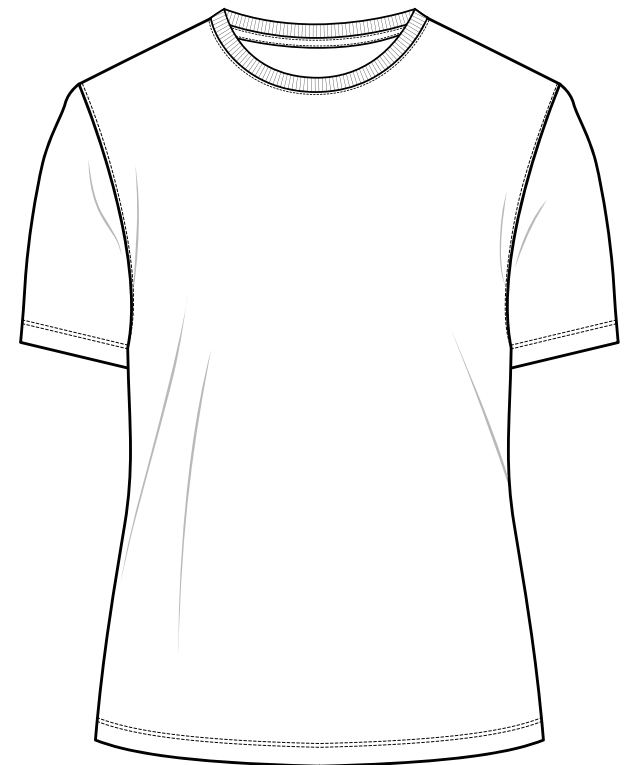

AVAILABLE COLORS



COTTON T-SHIRT, COLORS AVAILABLE
CUSTOMIZE TECHNIQUES
DTF, SERIGRAPHY AND SUBLIMATION





T-SHIRTS
US SIZE S M L XL 2XL 3XL



AVAILABLE COLORS



COTTON V-NECK T-SHIRT, COLORS AVAILABLE
CUSTOMIZE TECHNIQUES
DTF, SERIGRAPHY AND SUBLIMATION





T-SHIRTS
US SIZE S M L XL 2XL 3XL

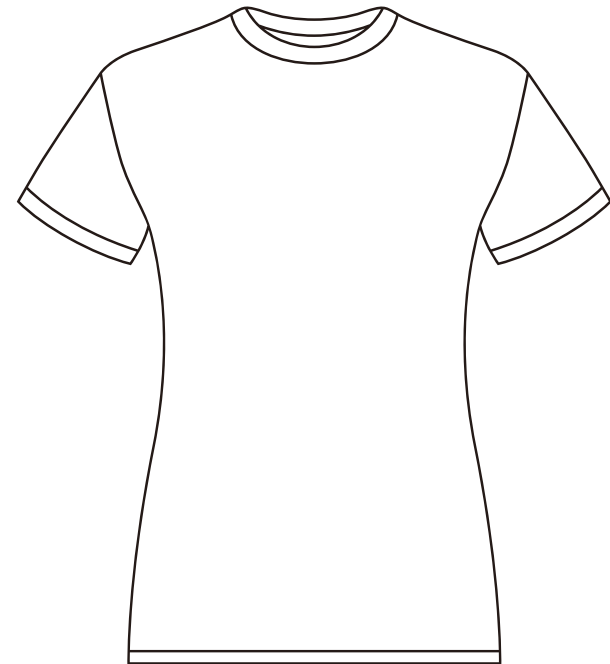

AVAILABLE COLORS



COTTON ROUND NECK T-SHIRT, COLORS AVAILABLE
CUSTOMIZE TECHNIQUES
DTF, SERIGRAPHY AND SUBLIMATION





T-SHIRTS
US SIZE S M L XL 2XL 3XL

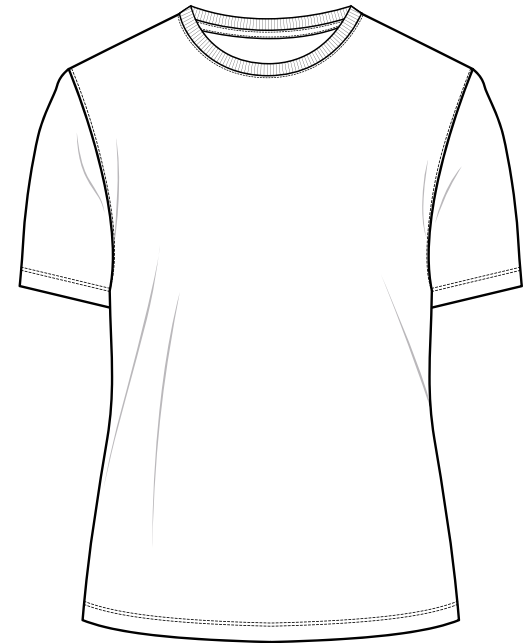

AVAILABLE COLORS



FULL COLOR COTTON T-SHIRT, COLORS AVAILABLE
CUSTOMIZE TECHNIQUES
DTF, SERIGRAPHY AND SUBLIMATION





T-SHIRTS
US SIZE S M L XL 2XL 3XL



AVAILABLE COLORS



POLO SHIRT, COLORS AVAILABLE
CUSTOMIZE TECHNIQUES
DTF, SERIGRAPHY AND SUBLIMATION





T-SHIRTS
US SIZE S M L XL 2XL 3XL

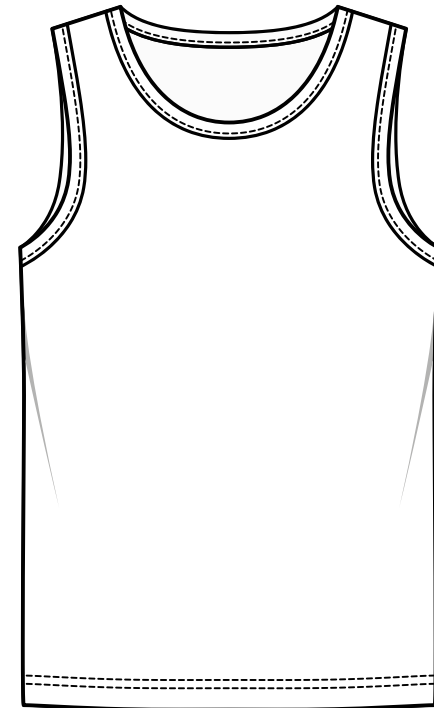

AVAILABLE COLORS



SLEEVELESS SHIRT, COLORS AVAILABLE
CUSTOMIZE TECHNIQUES
DTF, SERIGRAPHY AND SUBLIMATION



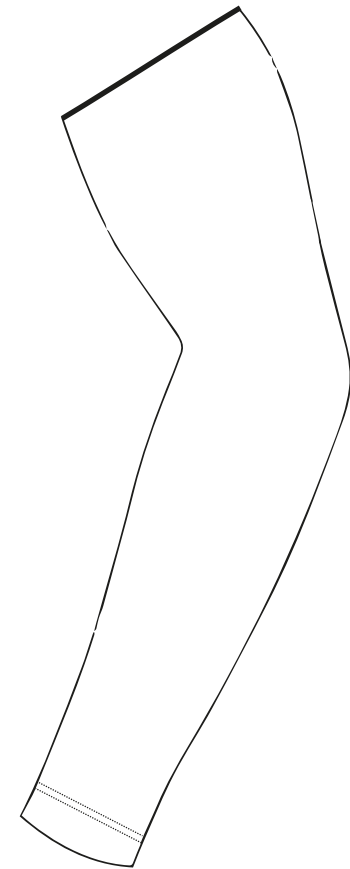

AVAILABLE COLORS



SPORTS SLEEVE COVER, COLORS AVAILABLE
CUSTOMIZE TECHNIQUES
DTF, SERIGRAPHY AND SUBLIMATION



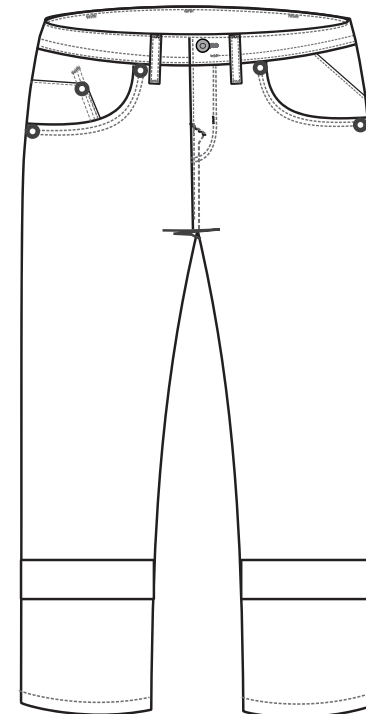

AVAILABLE COLORS



JEANS WITH REFLECTIVE LINES OR NORMAL JEANS
CUSTOMIZE TECHNIQUES
SERIGRAPHY AND SUBLIMATION



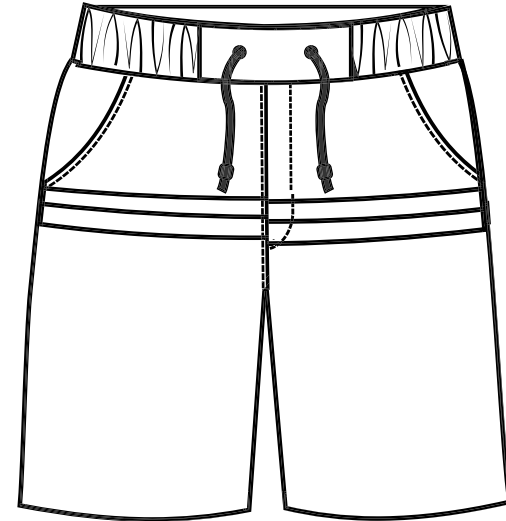

AVAILABLE COLORS



SHORTS, COLORS AVAILABLE
CUSTOMIZE TECHNIQUES
DTF, SERIGRAPHY AND SUBLIMATION





HOODIE

HOODIES
US SIZE S M L XL 2XL 3XL

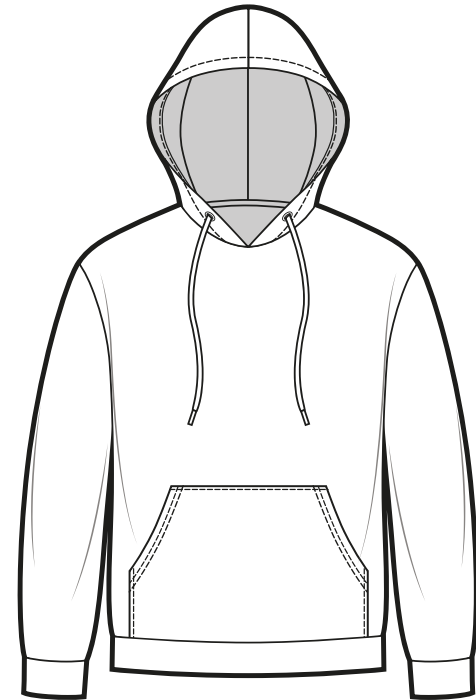

AVAILABLE COLORS



HOODIE COLORS AVAILABLE
CUSTOMIZE TECHNIQUES
DTF, SERIGRAPHY AND SUBLIMATION





T-SHIRTS
US SIZE S M L XL 2XL 3XL

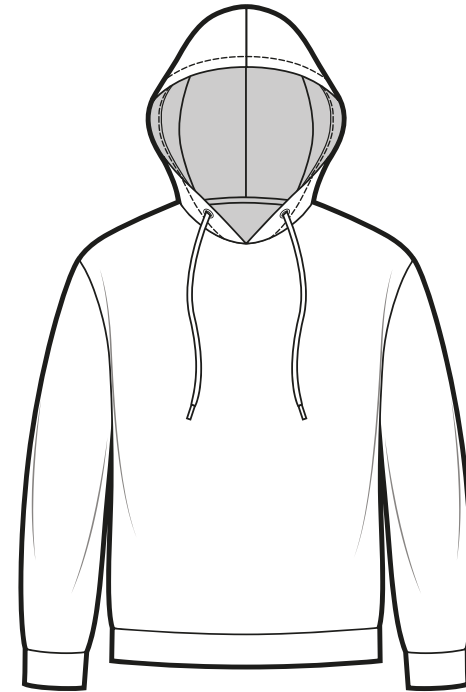

AVAILABLE COLORS



HOODIES, COLORS AVAILABLE
CUSTOMIZE TECHNIQUES
DTF, SERIGRAPHY AND SUBLIMATION



T-SHIRTS

US SIZE **S M L XL 2XL 3XL**



AVAILABLE COLORS



HOODIE WITH ZIPPER, COLORS AVAILABLE
CUSTOMIZE TECHNIQUES
DTF, SERIGRAPHY AND SUBLIMATION





T-SHIRTS
US SIZE S M L XL 2XL 3XL

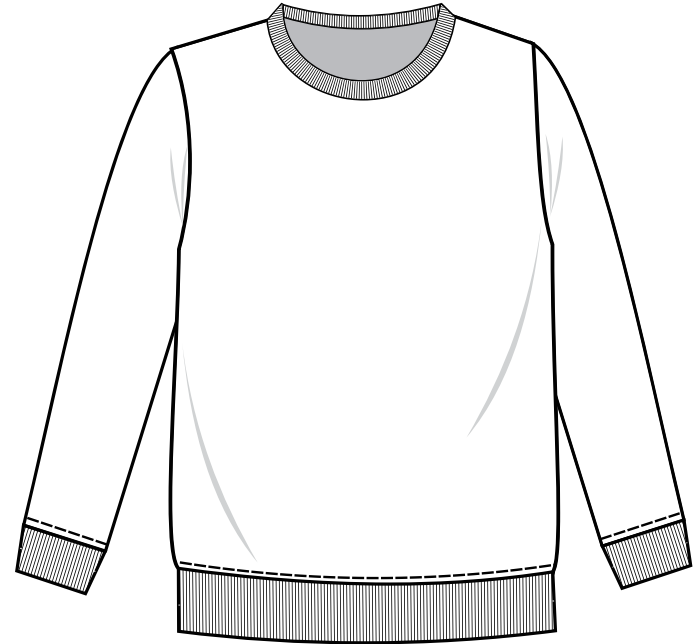

AVAILABLE COLORS



HOODIE, COLORS AVAILABLE
CUSTOMIZE TECHNIQUES
DTF, SERIGRAPHY AND SUBLIMATION



TOWEL

BOLSA COCIDA, TELA DE MANTA,
GOMASARRADON DE COLORES
VARIACION DE COLORES EN AGARRADOR



BEACH TOWEL

BAGSF01001



BEACH TOWEL
CUSTOMIZE TECHNIQUES
DTF, SERIGRAPHY, SUBLIMATION AND
EMBROIDERED

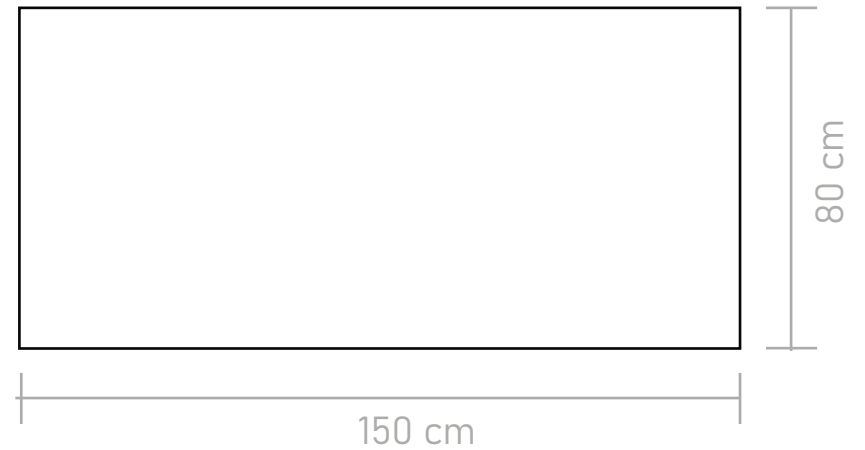

AVAILABLE COLORS



HANDS TOWEL

BAGSF01001



HANDS TOWEL

CUSTOMIZE TECHNIQUES
DTF, SERIGRAPHY, SUBLIMATION AND
EMBROIDERED

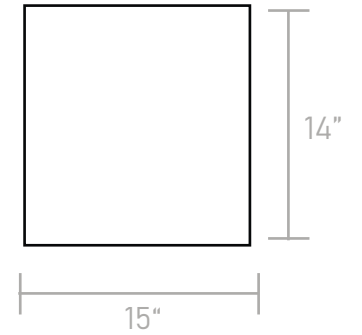
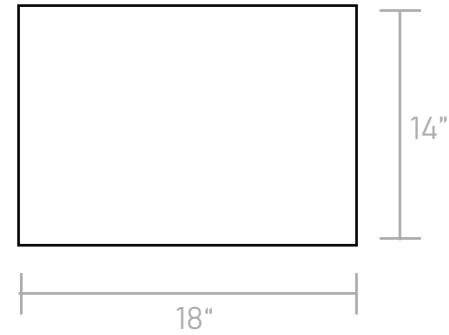

AVAILABLE COLORS





APRON

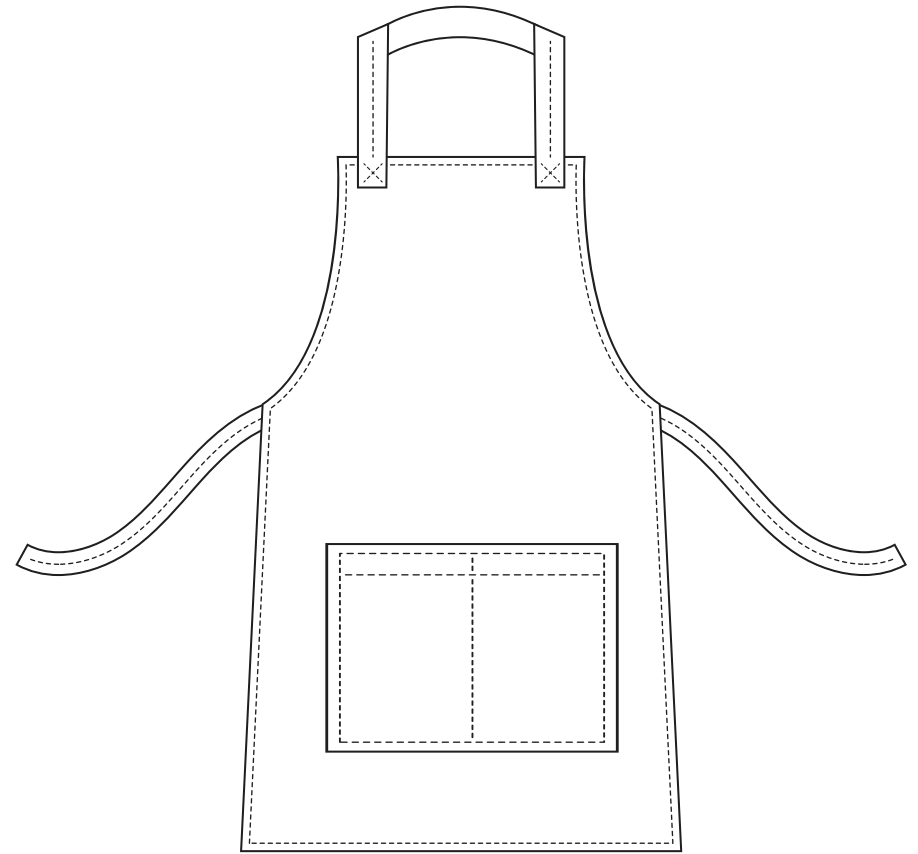

DENIM APRON
LIGHT AND DARK TONES AVAILA
CUSTOMIZE TECHNIQUES
DTF, SERIGRAPHY, SUBLIMATION AND
EMBROIDERED



CUSTOMIZABLE



TRENCH COAT APRON
CUSTOMIZE TECHNIQUES
DTF, SERIGRAPHY, SUBLIMATION AND
EMBROIDERED

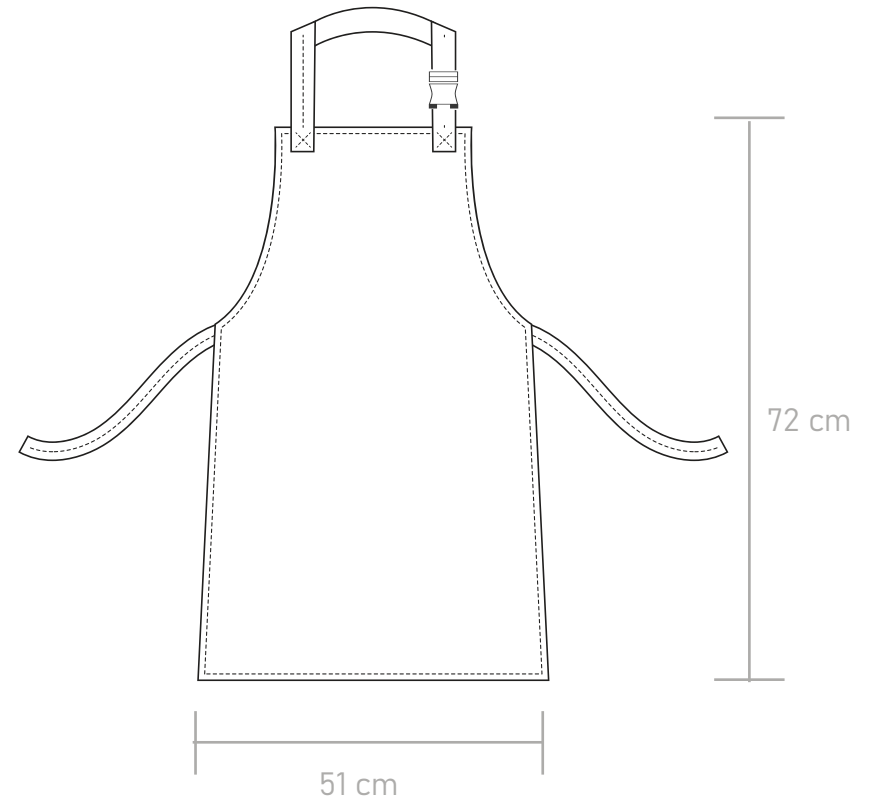

AVAILABLE COLORS





TRENCH COAT APRON
CUSTOMIZE TECHNIQUES
DTF, SERIGRAPHY, SUBLIMATION AND
EMBROIDERED

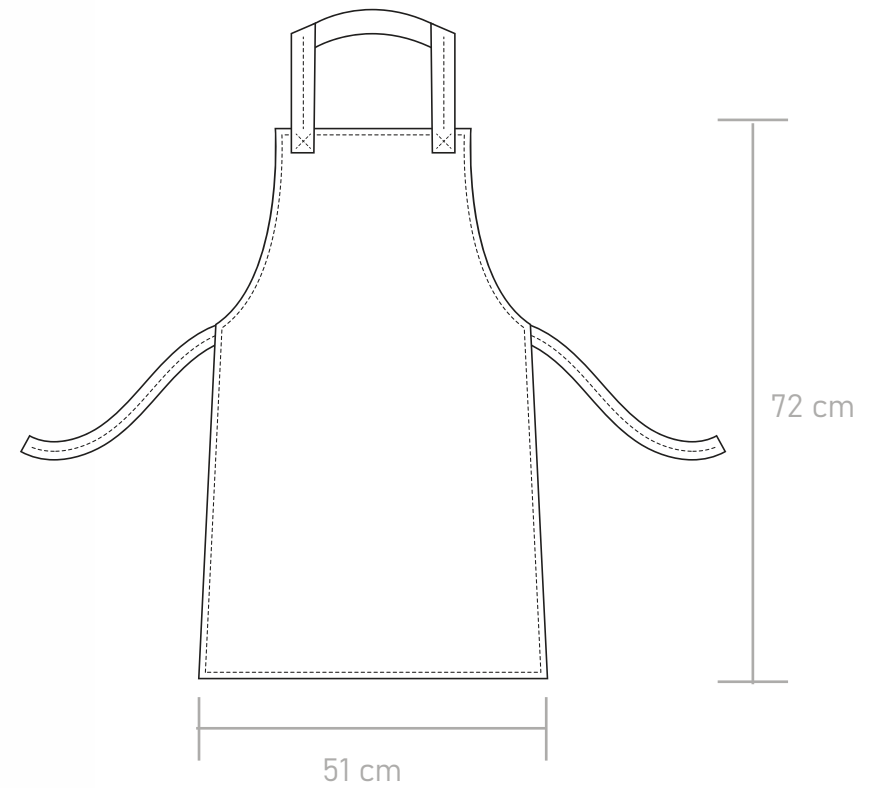

AVAILABLE COLORS



TRENCH COAT APRON WITH FRONT BAG
CUSTOMIZE TECHNIQUES
DTF, SERIGRAPHY, SUBLIMATION AND
EMBROIDERED

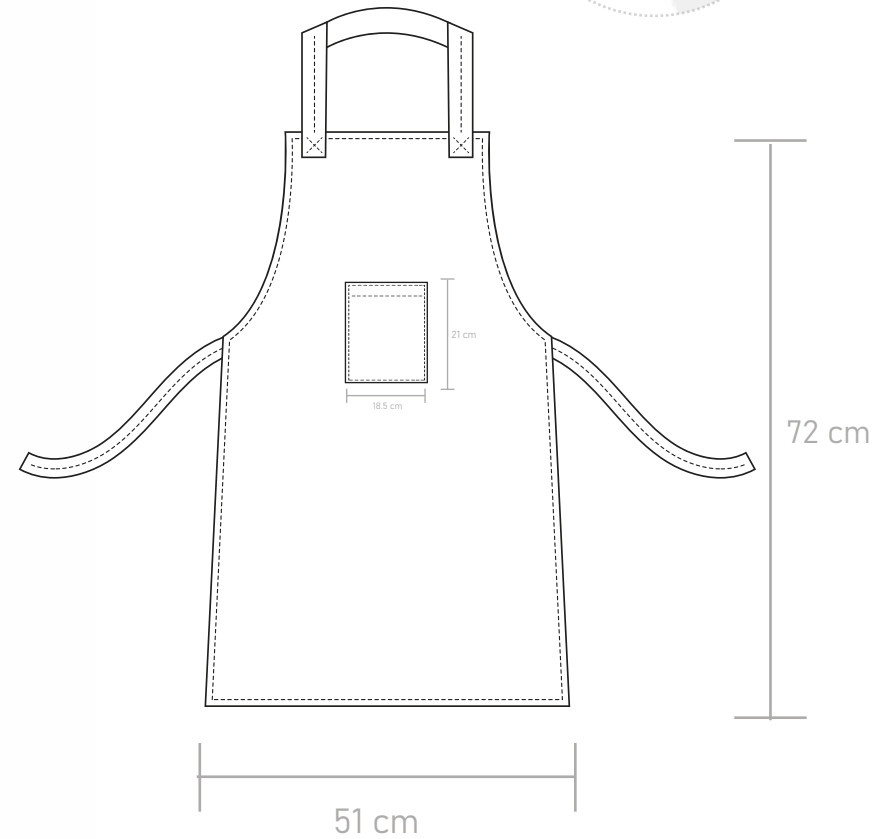

AVAILABLE COLORS





TRENCH COAT WITH FRONT BAGS
CUSTOMIZE TECHNIQUES
DTF, SERIGRAPHY, SUBLIMATION AND
EMBROIDERED

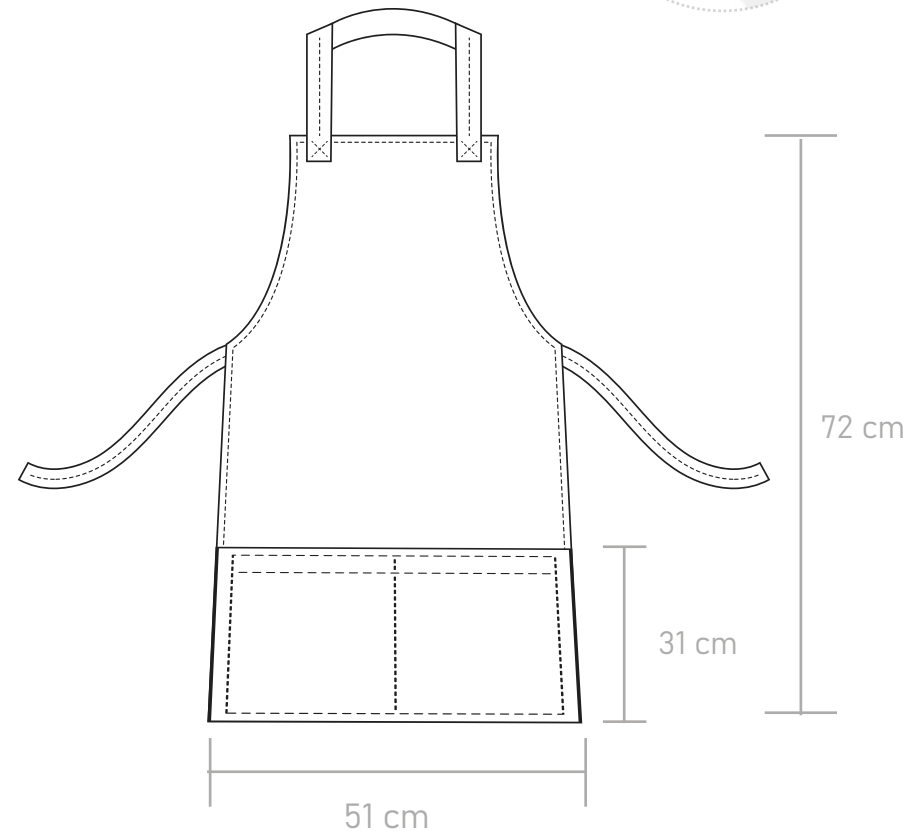

AVAILABLE COLORS



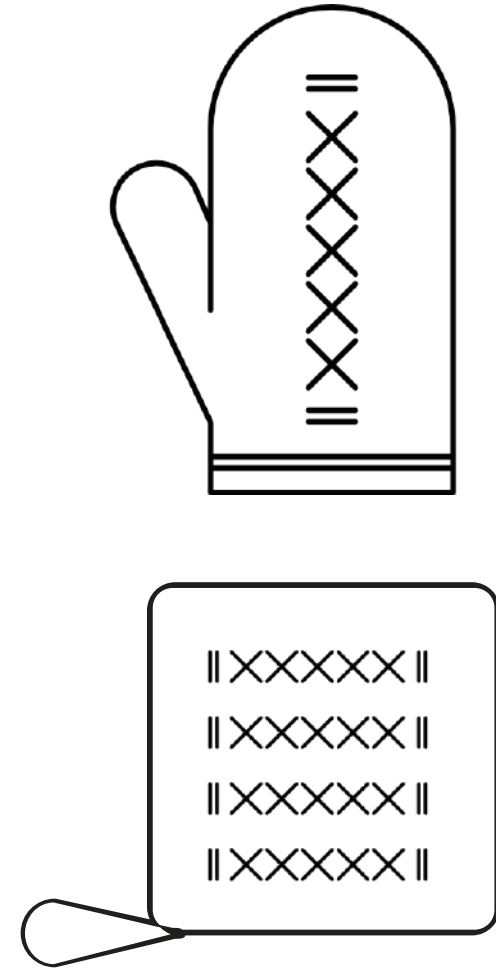

AVAILABLE COLORS



KITCHEN KIT
CUSTOMIZE TECHNIQUES
DTF, SERIGRAPHY, SUBLIMATION





CONFECTION



SERIGRAPHY



SUBLIMATION



PERSONAL COSMETICS BAG

BAGSF01001

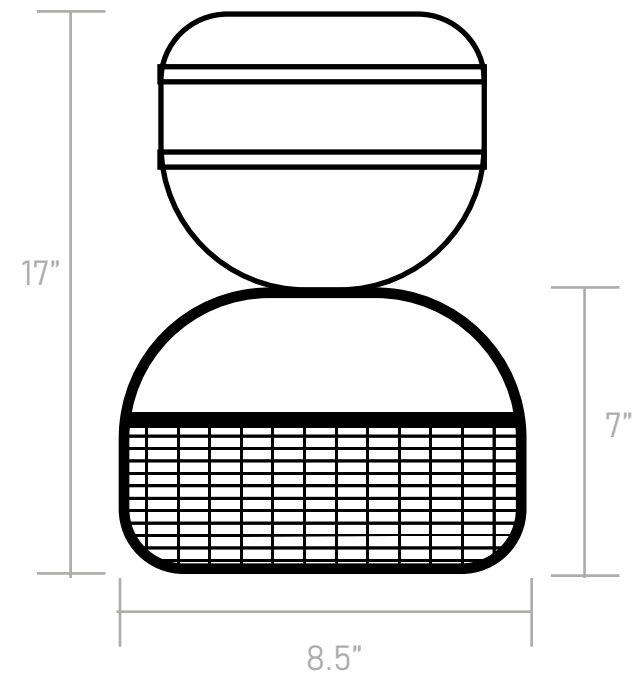

DOUBLE ZIPPER COSMETICS BAG

BAGSF01001



DOUBLE ZIPPER COSMETICS BAG

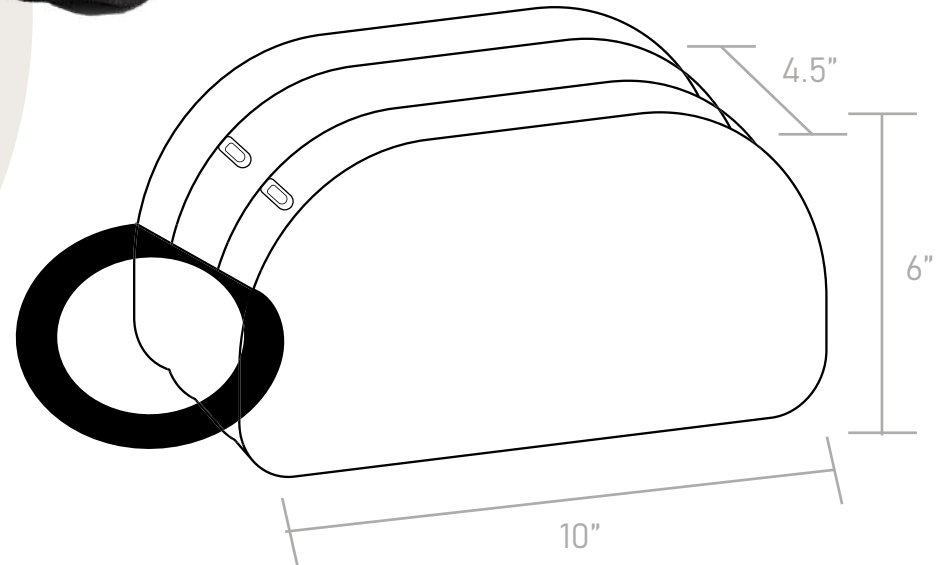



SHOES BAG
CUSTOMIZE TECHNIQUES
DTF, SERIGRAPHY, SUBLIMATION AND
EMBROIDERED

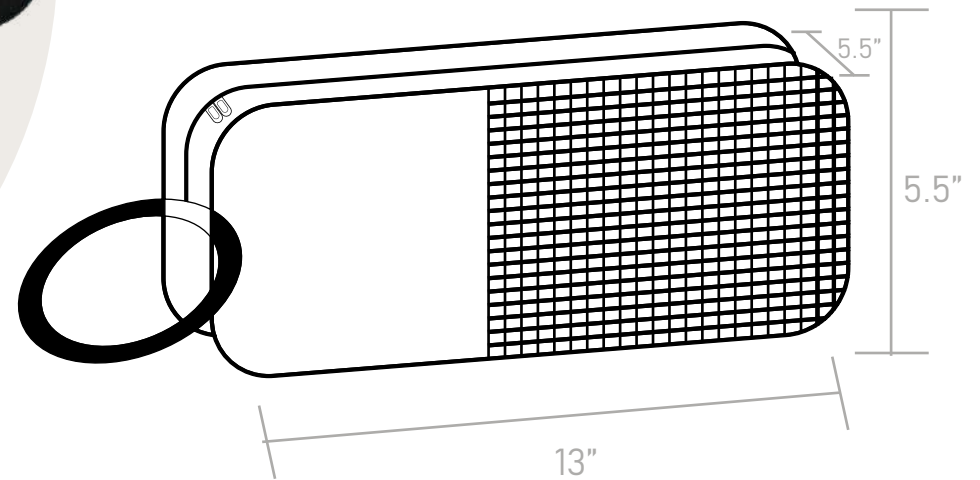

AVAILABLE COLORS



LUNCH BAG

BAGSF01001

LUNCH BAG WITH 3 COMPARTMENT
CUSTOMIZE TECHNIQUES
DTF, SERIGRAPHY, SUBLIMATION AND
EMBROIDERED

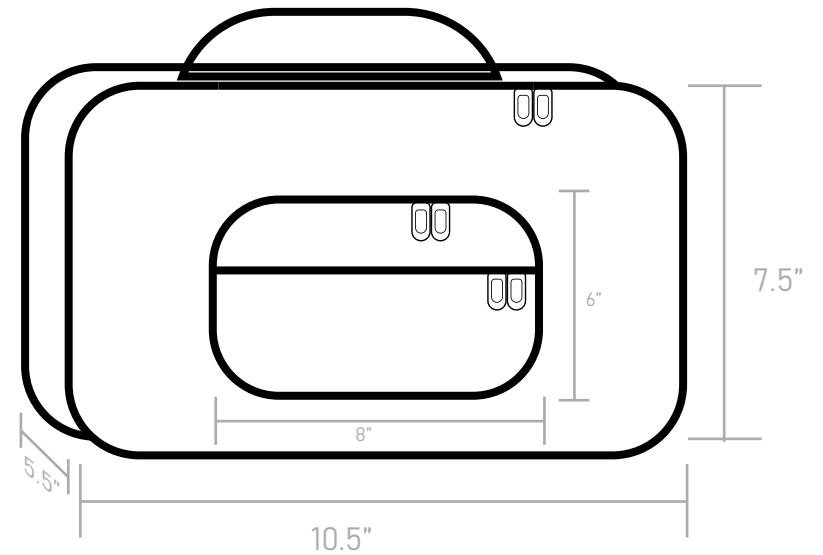

AVAILABLE COLORS



SCHOOL LUNCH BAG

BAGSF01001



SCHOOL LUNCH BAG WITH 2 COMPARTIMENT
CUSTOMIZE TECHNIQUES
DTF, SERIGRAPHY, SUBLIMATION AND
EMBROIDERED

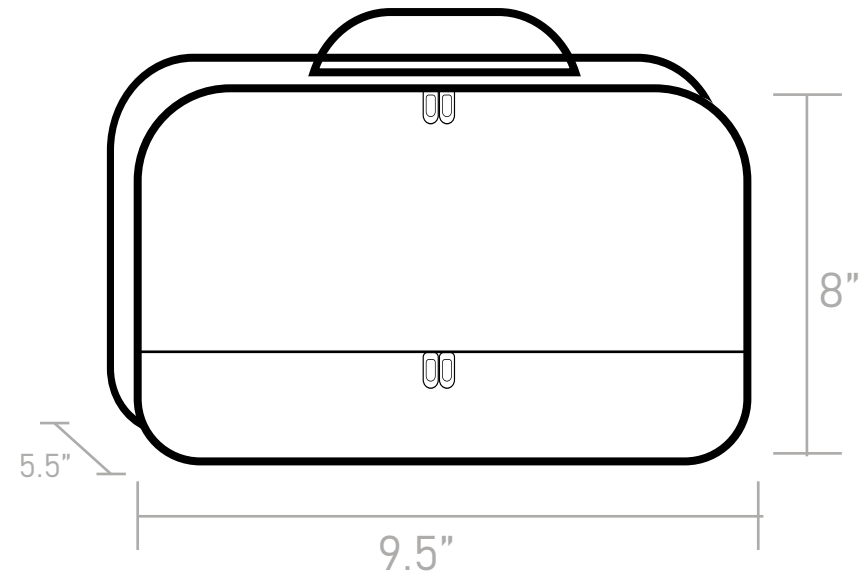

AVAILABLE COLORS



KIDS LUNCH BAG

BAGSF01001



KIDS LUNCH BAG
CUSTOMIZE TECHNIQUES
DTF, SERIGRAPHY, SUBLIMATION AND
EMBROIDERED

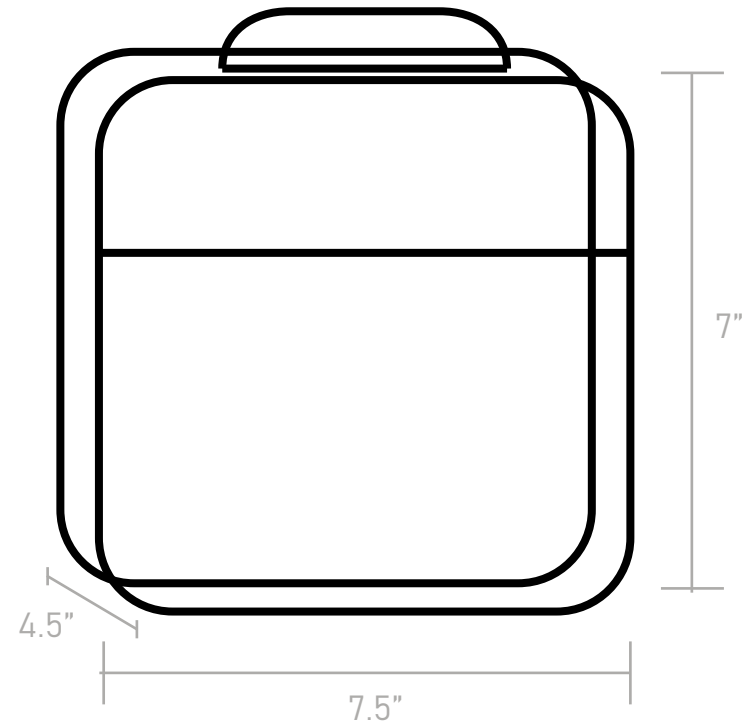

AVAILABLE COLORS



SQUARED LUNCH BAG

BAGSF01001

SQUARED LUNCH BAG
CUSTOMIZE TECHNIQUES
DTF, SERIGRAPHY, SUBLIMATION AND
EMBROIDERED

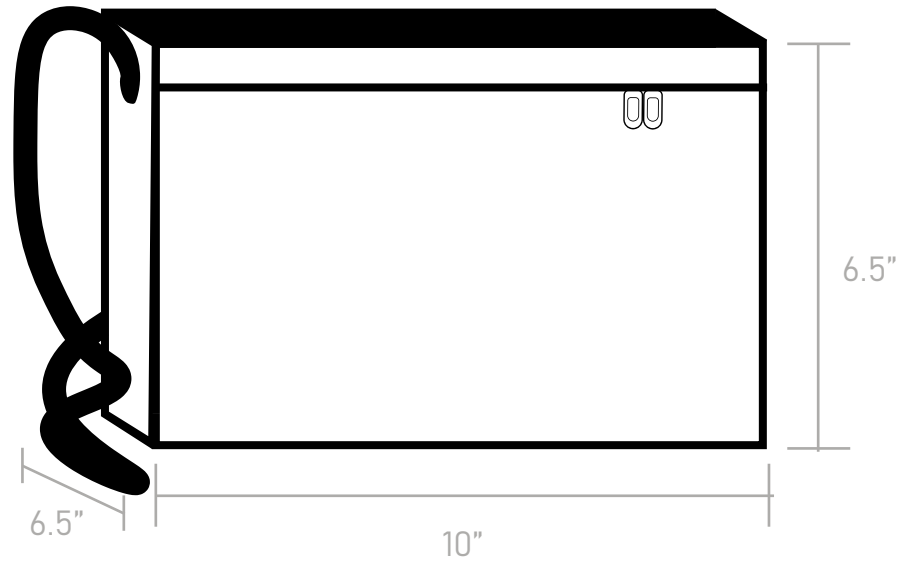

AVAILABLE COLORS



COMPACT LUNCH BAG

BAGSF01001

COMPACT LUNCH BAG
CUSTOMIZE TECHNIQUES
DTF, SERIGRAPHY, SUBLIMATION AND
EMBROIDERED

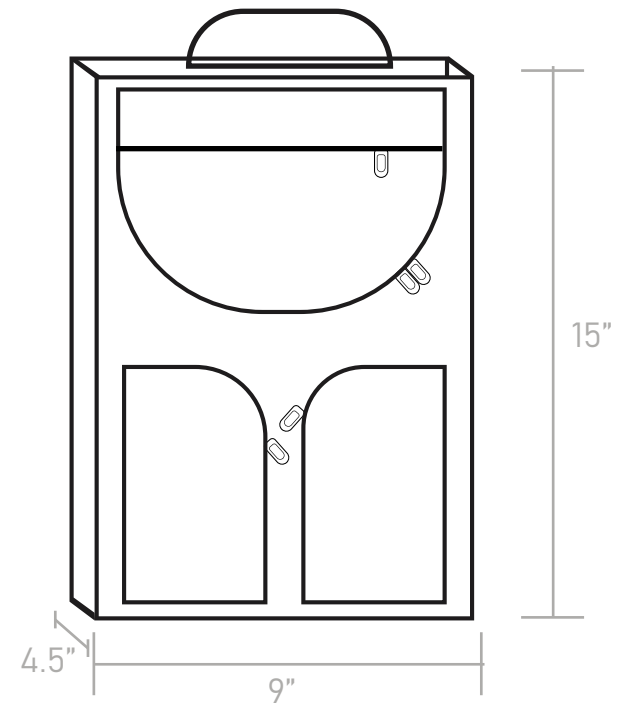

AVAILABLE COLORS





SPORTS BAG
CUSTOMIZE TECHNIQUES
DTF, SERIGRAPHY, SUBLIMATION AND
EMBROIDERED

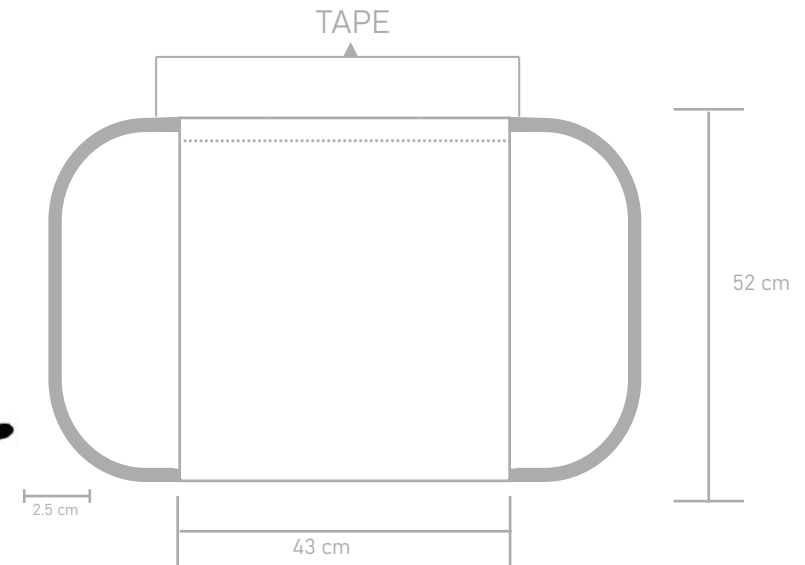

AVAILABLE COLORS



NEO DRINK HOLDER COVER

BAGSF01001

TERMIC NEO DRINK HOLDER COVER WITH REINFORCED BAGGERS, COLORS AVAILABLE, 6 BOTTLES CAPACITY
CUSTOMIZE TECHNIQUES
DTF, SERIGRAPHY, SUBLIMATION AND EMBROIDERED

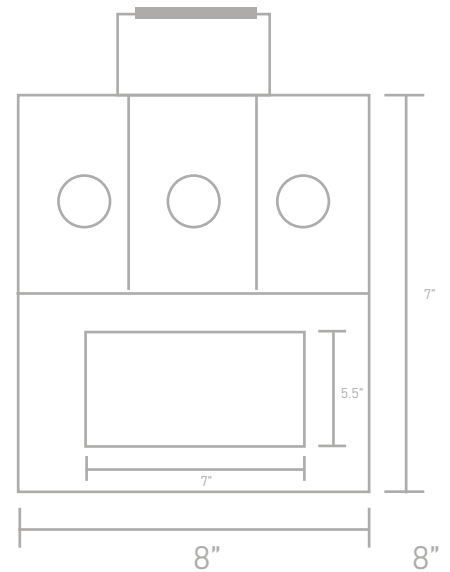

AVAILABLE COLORS



About Us

We are a textile company based in the United States with roots in Guatemala. Since our inception, we have strived to combine Guatemalan textile tradition with cutting-edge innovation and technology. Our commitment to quality and customer service has allowed us to grow and establish ourselves as leaders in the local textile market. Our team is composed of experts in the manufacturing field, focused on creating unique and high-quality products. We work with top-quality materials and use traditional techniques to ensure the durability of our products. At our company, we value diversity and inclusion, and we work hard to create a safe and fair work environment for all our employees. We are also committed to being environmentally responsible and using sustainable practices in all phases of our production process

Mission:

Mission:

Our mission is to provide our customers with high-quality, versatile textile products that are made with a commitment to sustainability and fair labor practices. We strive to continuously innovate and improve our products and processes, while staying true to our Guatemalan heritage.

Vision:

Our vision is to be globally recognized as a leading textile company that sets the standards for quality, style, and sustainability in the industry. We aspire to create a positive impact on our customers, employees, communities, and the planet, while continuing to grow and evolve as a responsible and innovative company.



Our Services

FULL PACKAGE

Your products tailored according to your needs from start to finish.

COMPUTARIZED EMBROIDERY

We use automation to ensure embroidery flexibility and quality.

DTF & SCREEN PRINTING

We accommodate different types of customization options, so our customers have a variety of services to choose from.

SUBLIMATION

We offer sublimation technology for high performance and polyester based fabrics.

We've Got You Covered!



CONTACT US

+1 (737) 910-3957

+(502) 2297 - 4400

sales@unitexapparel.com

United States | Guatemala | El Salvador | Honduras